

Development of an animal-drawn disc ridger for a tied ridging system of conservation tillage

by

Jürgen Hagmann

GTZ Conservation Tillage Project, PO Box 790, Masvingo, Zimbabwe

Abstract

Draft power and labour constraints in the communal areas of Zimbabwe make it difficult to implement tied ridging using the local winged ridger or mouldboard plow. In response to these problems an animal-drawn disc ridger was developed. Using this implement, draft and work time requirements were reduced by 45 and 40%, respectively. Although the implement is quite heavy, it contributes to an easier and less labour-intensive management of tied ridging. Its use is not limited to tied ridging as it can also be operated as a ridger for other ridging systems.

Introduction

A recent erosion survey in Zimbabwe showed that 27% of the total communal land could be classified as seriously or very seriously eroded (Whitlow, 1988). This fact demonstrates that protective measures taken against soil erosion during the past 50 years have not been effective. During this period, emphasis was given to preventing rill and gully erosion by contour layouts (storm drains, waterways and contour ridges). No measures have been taken against sheet erosion. However, a substantial part of the degradation in communal lands is due to arable sheet erosion between the contour ridges. Conservation tillage systems are therefore being developed to help prevent sheet erosion and so facilitate sustainable crop production.

A major constraint for tillage in communal areas is draft power. Droughts during the past decade have reduced the number of cattle and made them too expensive for many farmers. The existing animals are generally in a poor condition. Draft constraints are so severe that tillage operations such as plowing for planting are often much delayed at peak times, and such delays can contribute to complete crop failures. Therefore, conservation tillage systems are most likely to be successful if they require low draft power.

Tied ridging system

One conservation tillage system developed in Zimbabwe is known locally as “no-till tied ridging” (Elwell and Norton, 1988). Further research on

conservation tillage is presently being carried out by the Department of Agriculture, Technical and Extension Services (Agritex), assisted by the German Agency for Technical Cooperation (GTZ), in the Conservation Tillage for Sustainable Crop Production Systems Project, also known as “ConTil”.

The conservation tillage system is based on the conventional tied ridging system (Prestt, 1986) which is a type of basin tillage. Ridges and cross-dams (ties) in the furrows form basins which reduce surface runoff and thus conserve soil and water. In the conventional tied ridging system these ridges are plowed every year. In the “no-till” system the ridges are semi-permanent. Draft power requirements are less because, after the first year, only ridge maintenance and weeding have to be carried out.

In the first year the land is plowed to the recommended depth of 230 mm. Ridges about 900 mm wide and a minimum of 250 mm high are constructed either by an animal-drawn ridger or with a single furrow mouldboard plow (Elwell and Norton, 1988). Ridges are laid out at a grade of 1:250 to 1:100. Cross-ties, one-half to two-thirds of the height of the ridge, are made by hoe or low-cost tie-maker at intervals of about 1.5 m. In wet years, or in soils prone to waterlogging, the ties can be removed or allowed to break during storms in order to drain away excess water. Planting is carried out on top of the ridge once the ridge is moist throughout. Early weeding is achieved through re-ridging. After harvest, re-ridging is carried out in order to eliminate late weeds.

Problems of animal-powered tied-ridging

Tied ridging has performed well on research sites (Vogel, 1991) especially in terms of soil conservation. However, implementation of tied ridging using a conventional (high-wing) ox-drawn ridger proved to be draft-intensive. It was less draft-intensive but much more time-consuming if a plow was used. Other problems encountered during the preceding observational tillage trials (Stevens,

1989) and during the continuing adaptive on-farm trials (Gotora, 1991) were that:

- ridge tying requires another operation with draft animals provided a low-cost tie-maker is available. If not, ties must be built up by hoe which is extremely labour-intensive. In this regard it is understandable that some farmers with few resources, stopped ridge tying, although this operation is essential to the conservation objectives of this system
- timeliness of all operations suffers due to the time-consuming procedures involved. Untimely weeding is particularly serious, since late ox-powered weeding may fail, resulting either in high weed infestation or in investment in time-consuming manual weeding
- planting on ridges can be a problem: one labour-intensive procedure involves holing-out using a hoe. Making a planting furrow on the ridge using draft animals is less time-consuming, but is difficult, depending on the shape of the ridges.

Against this background it was clear that tied ridging was a new system that required more development if it was to be accepted by farmers in communal areas. Optimal animal-drawn implements were not yet available. Using the existing animal-drawn implements or manual operations, the system required more labour and draft power than most farmers have available.

Development of a disc ridger

In response to the problems mentioned, notably the high draft of the conventional (high-wing) ridger and long time requirement with a plow, it was decided to develop an animal-drawn disc ridger. This was intended to reduce both draft power and time requirements. In addition, the disc ridger was expected to fulfil the following criteria:

- ridge shape and size must be adequate: ridges must have a width of 900 mm, a height of at least 250 mm and a flat crest (like an inverted W)
- work efficiency in ridging, re-ridging and tying must be very much higher than with the present equipment. Re-ridging and tying ideally should be achieved in one operation. This would guarantee more timely operations
- weeding performance must be satisfactory
- the ridger should be easy to handle, to facilitate its use by the many old farmers now operating in communal areas
- design should be simple and robust

- the ridger should require very little maintenance (wear and tear should be at a minimum)
- the ridger must be affordable for communal farmers
- the ridger must be capable of being manufactured with locally available materials without the need for foreign currency
- where practicable, further attributes, such as self-cleaning, should be built into the ridger design.

With the above requirements in mind, a first prototype was designed and built. As soon as a prototype was found to perform well on-station, ridgers were given to farmers participating in on-farm trials. Ways of improving the implement according to the needs of potential users were intensively discussed with farmers, and appropriate changes were included in the next version. The present implement is a result of this step-by-step procedure which will continue in the future.

Technical design

The main difference between the disc ridger and a high-wing plow-ridger is the use of revolving discs for moving the soil. These reduce frictional resistance and draft power. The disc ridger consists of a main beam and a central crossed beam to which two adjustable discs are attached. A duckfoot tine is mounted in front, and behind is a tie-maker attached to a handle that can be lifted and dropped by the operator (see Figure 1). The disc ridger is pulled by a wooden draw bar which allows good control of the implement. All adjustments can be set without spanners. Bolts with handles or bolts pushed by spring mechanisms are used. The ridger can be operated in two different ways: ridging and re-ridging. Furthermore, the discs can be put to a transport position.

Figure 1: Components of the disc ridger
1: beam with draw bar attachment; 2: handle;
3: tie-maker; 4: attachments for distance between discs and disc angle; 5: king pins with disc shafts; 6: discs;
7: duckfoot-tine; 8: draw bar

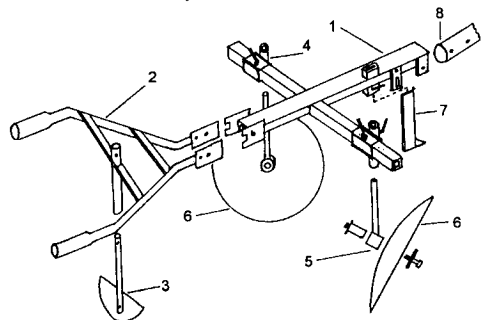



Photo: Jürgen Haggmann

Photo 1: Disc ridger in ridging mode

Ridging mode

For an initial installation of ridges the “ridging mode” is used (see Photo 1). The revolving discs scrape the pre-plowed soil into a ridge between the discs. The width and the height of the ridge can be varied by adjusting the disc angle and the distance between the discs. The handle is in a fixed position. If required, a ripper tine can be mounted on the tie-maker and can be used for ripping an additional line on top of the ridge (eg, for a planting furrow). The duckfoot tine in front can be adjusted to loosen the soil if required, or it can be left idle.

Re-ridging and tying

For re-ridging in the furrow (eg, for weeding or rebuilding an existing ridge), including tying, the “re-ridging mode” is applied (see Photo 2). In this position the revolving discs move soil from the furrow bottom to the flanks and, depending on the adjustment, on to the top of the ridge. The tine pulls in and loosens the soil in the furrow. Simultaneously the handle with the attached tie-maker is pressed down and lifted up every three steps. By doing so, soil in the furrow is pushed to form ties at a spacing of approximately 1.5 m. Re-ridging and tying are achieved in one operation. The same position can be applied for installing ridges, but for this purpose handling is less stable than with the ridging mode.

Transport position

For transport the discs are set parallel to the main beam with the tine and tie-maker put up. The discs are used as wheels so the ridger can be transported for short distances like a cart.

Size of discs

The frictional resistance of the discs depends mainly on the revolving movement which turns into a pushing movement the more the disc angle (angle to the direction of travel) is increased. For creation of



Photo: Jürgen Haggmann

Photo 2: Disc ridger in re-ridging and ridge-tying mode

900 mm wide ridges, larger diameter discs need a narrow disc angle (leading to lower frictional resistance and lower draft requirement than smaller discs). The main disadvantage of big discs is their weight. The price difference between small and large discs is small. A suitable compromise for tied ridging was found to be a diameter of about 60 cm, available locally as “26 inch” discs for tractor plows.

Tilt angle

The tilt angle (disc inclination angle) which determines the slope of the ridge shoulder has experimentally been found to have its optimum at 28° for both positions (ridging and re-ridging). This angle was fixed in order to make manufacturing easier and to avoid the necessity for many adjustments.

Weight

Due to the poor quality of available steel, the weight of the implement is 81 kg. Using high quality steel (not currently available in Zimbabwe), the weight could be reduced by about 30% without loss of strength. As a comparison, the high-wing ridger weighs 43 kg, while the conventional plow weighs 41 kg.

Practical experience

Handling and operational performance

A comparative test of the disc ridger along the lines recommended by Nazare and Norton (1988) for plow ridgers has not yet been carried out. The experience of the use of the disc ridger recorded in this paper is based on the feedback given by 16 farmers who participated in on-farm trials. From these trials and the on-station experience the following conclusions can be drawn so far.

Table 1: Comparison of draft and work requirements for ridging with different implements

	Ridging		Tying ¹		Ridging and tying	Re-ridging		Re-ridging and tying
	Mean draft (kN)	Time (hours/ha)	Mean draft (kN)	Time (hours/ha)	Time (hours/ha)	Mean draft (kN)	Time (hours/ha)	Time (hours/ha)
Disc ridger	0.96	4.7	0.53	3.2	7.9	1.24	5.2	5.2 ²
High-wing ridger	1.73	5.8	0.53	3.2	9.0	1.76	5.5	8.7
Inkunzi plow	1.37	11.0	0.53	3.2	14.2	1.46	11.8	15.0

¹Using low cost tiemaker²Simultaneous re-ridging and tying

Ridging

Ridge shape and size fully correspond to the required specifications. Ridge height mainly depends on depth of previous plowing. However, even on shallow plowed fields satisfactory results could be obtained. Ridge formation was very precise and homogeneous ridges and spacings were obtained, especially with the ridging mode. Handling during operation proved to be very good. Old farmers as well as women could operate it easily. A disadvantage of this mode is that an extra operation is needed for tying.

Re-ridging and tying

With proper adjustment (depending on crusting of soil) re-ridging results were found to be good. Simultaneous tying by lifting the tie-maker up and down gave good results as well. Handling during this operation requires a stronger control than in the ridging mode. Initially, farmers found it difficult to simultaneously re-ridge and tie. When they had more experience (each of them found their own best technique) they classified the operation as easy. Improperly trained oxen caused the major problem. The disc ridger, being mainly controlled through the draw bar, should only be operated with well-trained oxen.

Maintenance and wear

The bearings of the disc shafts should be lubricated once or twice a season depending on the size of the

tilled area. Wear is spread over the entire circumference of the discs and is relatively light.

Draft power and work time requirement

Draft power requirements were quantified on-station. Farmers' experience supported the on-station results as they considered the ridger to be a "light" implement to use. Farmers accustomed to using donkeys as draft animals used donkeys for ridging and re-ridging. Both operations could be well managed by one pair of donkeys. Results of a draft power test are shown in Table 1.

For ridging, draft power required for the disc ridger was 45% less than for the high-wing ridger and 30% less than for the plow. For re-ridging, the disc ridger with the attached tie-maker reduced draft power by 30% compared to the high-wing ridger and by 15% compared to the plow. Work time requirements for re-ridging and tying could be cut down by 40% compared to the high-wing ridger and by 65% compared to the plow. These results show that the disc ridger has a high potential for conditions with low draft power.

Cost efficiency

So far, the disc ridger has not been manufactured commercially. A tentative estimate for end-user price following serial manufacture in Zimbabwe was 750 Zimbabwe dollars (Z\$) or US\$ 150 (November 1991 prices). For comparison, prices for the most common animal-drawn farm implements are shown in Table 2.

The disc ridger is 68% more expensive than the high-wing ridger. For resource-poor communal farmers it will definitely be a big investment considering the prices they actually get for their products. Therefore, farmers who have already experienced the advantages and benefits of tied ridging will be the potential buyers.

In the long term the disc ridger should be financially rewarding. Savings in draft power and labour (which often must be hired) and yield benefits due

Table 2: Average prices for animal-drawn farm implements in Zimbabwe, November 1991

	Z\$	US\$
Disc ridger	750	150
High-wing ridger	445	89
Inkunzi plow	214	43
Cultivator	345	69
Planter	920	184
Animal-drawn cart	2196	440

to timely operations could contribute to a reasonable amortisation of the ridger. Farmers are often willing to invest after good seasons when they have buying power. For example, many farmers bought new animal-drawn carts after high yields in the 1989/90 season.

It will mainly be those progressive farmers with some resources and who perceive the advantages of tied ridging who would be potential buyers of the disc ridger. Some small-scale commercial farmers who saw the implement were very interested in buying it.

Conclusion

The disc ridger contributes to an easier and less labour-intensive management of tied ridging. While a conclusive comparative test of the disc ridger has yet to be carried out, practical experience indicates that it satisfies most of the identified requirements with respect to ease and timeliness of operations.

The most important advantage is the reduction in time required for ridging and for re-ridging and tying. This will enable farmers to cope with cultivation of their land in a much shorter period of time. As a result, other farming activities can also be carried out with greater timeliness. Other implements which reduce time and labour must also be developed in order to make the conservation tillage system attractive to farmers.

The second essential advantage is the greatly reduced draft power required for this ridger compared to the high-wing ridger. This is particularly important for drought prone areas where draft power is very limited. In these areas, numerous donkeys are available and cheap, whereas oxen are often too expensive for farmers. Therefore implements must be light enough to be pulled by donkeys. The disc ridger fulfils this condition. However, while donkeys are widely used to pull

carts, their use for tillage purposes has yet to be widely adopted.

The use of this disc ridger is not limited to tied ridging. It is possible to set the disc ridger for different dimensions of ridges. Therefore, this implement might be of interest not only for communal farmers but also for small-scale commercial farmers. It could also be used as an animal-drawn tobacco ridger.

Acknowledgements

The development of the disc ridger was greatly assisted by the dedicated work of Mr Gloss (Masvingo) whose technical competence contributed greatly to the present design. In addition, the support of farmers in Zaka and Chivi Districts and of the ConTil team is gratefully acknowledged.

References

- Elwell H A and Norton A, 1988. *No-till tied-ridging: a recommended sustained crop production system*. Institute of Agricultural Engineering, Department of Agricultural, Technical and Extension Services (Agritex), Harare, Zimbabwe. 39p.
- Gotora P, 1991. Adaptive no-till tied ridging trials in small-scale farming areas of Zimbabwe. pp. 410-416 in: *Soil tillage and agricultural sustainability*. Proceedings of the 12th International Conference of the International Soil Tillage Research Organisation (ISTRO), held July 1991, Ibadan, Nigeria. Ohio State University, Columbus, Ohio, USA.
- Nazare R M and Norton A J, 1988. *Evaluation of ox-drawn ridgers*. Institute of Agricultural Engineering, Department of Agricultural, Technical and Extension Services (Agritex), Harare, Zimbabwe. 12p.
- Prest A J, 1986. Basin tillage: a review. *Zimbabwean Agricultural Journal* 83(1).
- Stevens P A, 1989. *Observational tillage trials*. Paper presented at the Agritex Technical Conference, 16-20 October 1989, Nyanga, Zimbabwe. [Available from the Institute of Agricultural Engineering, Department of Agricultural, Technical and Extension Services (Agritex), Harare, Zimbabwe]
- Vogel H, 1991. *Conservation tillage for sustainable crop production systems*. Project Research Report 2. Institute of Agricultural Engineering, Department of Agricultural, Technical and Extension Services (Agritex), Harare, Zimbabwe. 38p.
- Whitlow R, 1988. *Land degradation in Zimbabwe: a geographical study*. Report prepared on behalf of the Department of Natural Resources, Harare, Zimbabwe. 62p.